

## '1A' Type

(3 Roller, Single Belling Roller Type)

### Order Instructions

To ascertain the correct tool number for your purposes, first establish the minimum bore which the tool enters (1st column of table below). Then select the appropriate Seat Thickness column, and read off at the Minimum Bore size line ... e.g. for a tube with minimum bore size of 40mm and a seat thickness of 35m the tool number will read: 1A40/35.

Intermediate range tools are available to special order:



MIN BORE TOOL ENTERS		MAX EXPN OF TOOL		MIN HAND HOLE SIZE TOOL ENTERS		TUBE SEAT THICKNESS					
						20mm ·787"	25mm ·985"	30mm 1·181"	35mm 1·378"	40mm 1·575"	45mm 1·772"
mm	inch	mm	inch	mm	inch	TOOL NUMBER					
15	.591	17.5	.689	35	1.378	1A15/20	1A15/25	1A15/30	1A15/35	1A15/40	1A15/45
16	.630	18.9	.744	35	1.378	1A16/20	1A16/25	1A16/30	1A16/35	1A16/40	1A16/45
17	.669	20.3	.799	36	1.418	1A17/20	1A17/25	1A17/30	1A17/35	1A17/40	1A17/45
18	.709	21.5	.846	37	1.457	1A18/20	1A18/25	1A18/30	1A18/35	1A18/40	1A18/45
19	.748	22.1	.870	38	1.500	1A19/20	1A19/25	1A19/30	1A19/35	1A19/40	1A19/45
20	.787	23.5	.925	39	1.536	1A20/20	1A20/25	1A20/30	1A20/35	1A20/40	1A20/45
21	.827	24.7	.972	40	1.575	1A21/20	1A21/25	1A21/30	1A21/35	1A21/40	1A21/45
22	.866	26.5	1.043	42	1.654	1A22/20	1A22/25	1A22/30	1A22/35	1A22/40	1A22/45
23.5	.925	28.3	1.114	44	1.732	1A23/20	1A23/25	1A23/30	1A23/35	1A23/40	1A23/45
25	.984	29.8	1.173	45	1.772	1A25/20	1A25/25	1A25/30	1A25/35	1A25/40	1A25/45
27	1.063	31.8	1.252	47	1.850	1A27/20	1A27/25	1A27/30	1A27/35	1A27/40	1A27/45
29	1.142	33.8	1.331	49	1.929	1A29/20	1A29/25	1A29/30	1A29/35	1A29/40	1A29/45
31	1.220	36.5	1.437	52	2.047	1A31/20	1A31/25	1A31/30	1A31/35	1A31/40	1A31/45
33	1.300	38.5	1.516	54	2.126	1A33/20	1A33/25	1A33/30	1A33/35	1A33/40	1A33/45
35	1.378	42.5	1.673	58	2.284	1A35/20	1A35/25	1A35/30	1A35/35	1A35/40	1A35/45
37	1.457	43.3	1.704	60	2.363	1A37/20	1A37/25	1A37/30	1A37/35	1A37/40	1A37/45
40	1.575	47.7	1.877	64	2.520	1A40/20	1A40/25	1A40/30	1A40/35	1A40/40	1A40/45
43	1.693	51.9	2.043	68	2.678	1A43/20	1A43/25	1A43/30	1A43/35	1A43/40	1A43/45
46	1.811	54.9	2.161	72	2.835	1A46/20	1A46/25	1A46/30	1A46/35	1A46/40	1A46/45
49	1.930	57.9	2.279	74	2.914	1A49/20	1A49/25	1A49/30	1A49/35	1A49/40	1A49/45
52	2.047	60.9	2.397	78	3.071	1A52/20	1A52/25	1A52/30	1A52/35	1A52/40	1A52/45
56	2.205	63.9	2.515	80	3.150	1A56/20	1A56/25	1A56/30	1A56/35	1A56/40	1A56/45
60	2.362	68.9	2.712	85	3.347	1A60/20	1A60/25	1A60/30	1A60/35	1A60/40	1A60/45
64	2.520	72.9	2.870	89	3.504	1A64/20	1A64/25	1A64/30	1A64/35	1A64/40	1A64/45
68	2.678	76.3	3.003	92	3.622	1A68/20	1A68/25	1A68/30	1A68/35	1A68/40	1A68/45
72	2.835	80.3	3.161	96	3.780	1A72/20	1A72/25	1A72/30	1A72/35	1A72/40	1A72/45
76	2.992	84.5	3.326	103	4.056	1A76/20	1A76/25	1A76/30	1A76/35	1A76/40	1A76/45
80	3.149	88.5	3.484	106	4.174	1A80/20	1A80/25	1A80/30	1A80/35	1A80/40	1A80/45
84	3.307	92.5	3.641	110	4.331	1A84/20	1A84/25	1A84/30	1A84/35	1A84/40	1A84/45
88	3.465	96.5	3.799	114	4.489	1A88/20	1A88/25	1A88/30	1A88/35	1A88/40	1A88/45
92	3.622	110.5	3.956	118	4.646	1A92/20	1A92/25	1A92/30	1A92/35	1A92/40	1A92/45
96	3.780	104.5	4.114	122	4.803	1A96/20	1A96/25	1A96/30	1A96/35	1A96/40	1A96/45
100	3.937	108.5	4.271	125	4.922	1A100/20	1A100/25	1A100/30	1A100/35	1A100/40	1A100/45

### WICKSTEED ENGINEERING LIMITED

Hove Road, Rushden, Northamptonshire NN10 0JB • Tel: +44 (0)1933 318555 • Fax: +44 (0)1933 410103 • Email: mail@wicksteed.com  
www.wicksteed.com

# '1A' Type

(continued)

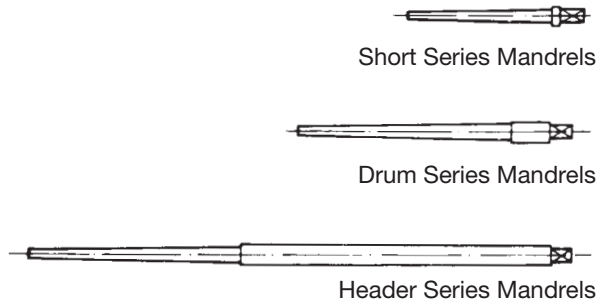

Drum mandrels will be supplied unless header or short series mandrels are ordered.

**Note:** In all cases the effective parallel rolling lengths of these tools is 9mm longer than the seat thickness dimensions given in the tables. Where it is necessary to expand in seats which are thicker than those covered below, the recommended procedure for rolling in thick drums applies.

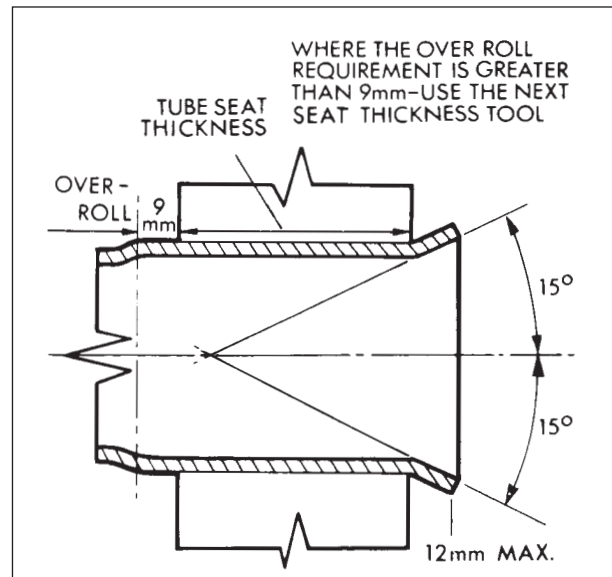

MIN BORE TOOL ENTERS		TUBE SEAT THICKNESS			Mandrel Size ■	DRUM MANDREL	HEADER MANDREL	SHORT MANDREL	EXTRA SHORT MANDREL
		50mm 1.969"	60mm 2.362"	70mm 2.756"					
mm	inch	TOOL NUMBER			inch				
15	.591				3/8	DA1	HA1	SA1/2	ESA1/2/3
16	.630					225mm lg	450mm lg	145mm lg	125mm lg
17	.669					8.858" lg	17.717" lg	5.709" lg	4.921" lg
18	.709								
19	.748				3/8	DA2	HA2	SA3/4	ESA4/5/6
20	.787					255mm lg	450mm lg	160mm lg	135mm lg
21	.827					10.039" lg	17.717" lg	6.299" lg	5.315" lg
22	.866								
23.5	.925				1/2	DA3	HA3	SA5/6	ESA7/8/9
25	.984					225mm lg	450mm lg	160mm lg	135mm lg
27	1.063					10.039" lg	17.717" lg	6.299" lg	5.315" lg
29	1.142								
31	1.220				3/4	DA4	HA4	SA7/8	ESA10/11/12
33	1.300					350mm lg	500mm lg	214mm lg	174mm lg
35	1.378					13.780" lg	19.685" lg	8.425" lg	6.850" lg
37	1.457	1A37/50	1A37/60	1A37/70	3/4	DA5	HA5	SA9/10	ESA13/14/15
40	1.575	1A40/50	1A40/60	1A40/70		355mm lg	550mm lg	225mm lg	185mm lg
43	1.693	1A43/50	1A43/60	1A43/70		13.976" lg	21.654" lg	8.858" lg	7.284" lg
46	1.811	1A46/50	1A46/60	1A46/70					
49	1.930	1A49/50	1A49/60	1A49/70	3/4	DA6	HA6	SA11/12	ESA16/17/18
52	2.047	1A52/50	1A52/60	1A52/70		355mm lg	550mm lg	225mm lg	185mm lg
56	2.205	1A56/50	1A56/60	1A56/70		13.976" lg	21.654" lg	8.858" lg	7.294" lg
60	2.362	1A60/50	1A60/60	1A60/70					
64	2.520	1A64/50	1A64/60	1A64/70	1	DA7	HA7	SA13/14	ESA19/20/21
68	2.678	1A68/50	1A68/60	1A68/70		355mm lg	550mm lg	225mm lg	185mm lg
72	2.835	1A72/50	1A72/60	1A72/70		13.976" lg	21.654" lg	8.858" lg	7.284" lg
76	2.992	1A76/50	1A76/60	1A76/70					
80	3.149	1A80/50	1A80/60	1A80/70	1	DA8	HA8	SA15/16	ESA22/23/24
84	3.307	1A84/50	1A84/60	1A84/70		355mm lg	550mm lg	225mm lg	185mm lg
88	3.465	1A88/50	1A88/60	1A88/70		13.976" lg	21.654" lg	8.858" lg	7.284" lg
92	3.622	1A92/50	1A92/60	1A92/70					
96	3.780	1A96/50	1A96/60	1A96/70					
100	3.937	1A100/50	1A100/60	1A100/70					

## WICKSTEED ENGINEERING LIMITED

Hove Road, Rushden, Northamptonshire NN10 0JB • Tel: +44 (0)1933 318555 • Fax: +44 (0)1933 410103 • Email: mail@wicksteed.com  
www.wicksteed.com